

stored energy solutions for a demanding world



Model: **70PzV500**

Ares series

Ares range battery adopts traditional tubular gel technology, adopts patent gel electrolyte. The products are used as standby power for communication, power, military and broadcast and television system. They possess precise ABS heat seal technology between container and lid and patented post seal structure. Provide better deep cycle performance versus AGM. The design float life is 18+ years.



Specifications

Battery Model	70PzV500
Nominal Voltage	2V
Rated Capacity	500Ah (10hour rate) to 1.80V/cell @25°C(77°F)
Typical Weight	41kg
Internal Resistance	Approx 0.495mΩ
Operating Temperature Range	Operation(maximum) : -40°C to 55°C(-40°F to 131°F)
	Operation(recommended) : 15°C to 25°C(59°F to 77°F)
	Storage : -20°C to 40°C(-4°F to 104°F)
Float Voltage	2.23V/cell@25°C(77°F)
Charge Current	50A(Recommendation) 125A(Maxmum)
Equalize and Cycle Service	2.35V~2.40V/cell@25°C(77°F)
Self Discharge	The residual capacity is above 94% after 90 days storage(25°C/77°F)
Terminal	M8 Female Large Size Copper Post
Terminal Hardware Torque	15 ± 1.0Nm
Container Material	ABS (V0 optional)

Discharge Data with Constant Current Units : Amperes (25°C, 77°F)

End voltage	15min	30min	1h	2h	3h	4h	5h	6h	8h	10h	16h	24h	48h	100h
1.60V	543	433	297	184	133	105	90.3	79.4	64.0	52.5	33.9	23.5	12.9	7.2
1.65V	524	419	290	180	131	104	89.3	78.5	63.5	52.2	33.7	23.5	12.8	7.1
1.70V	493	402	281	176	129	103	88.1	77.2	62.8	52.0	33.5	23.3	12.7	7.0
1.75V	468	387	273	172	126	101	86.6	75.7	61.6	51.2	33.0	22.8	12.6	6.8
1.80V	413	354	260	165	123	99	84.6	73.8	60.2	50.0	32.1	22.3	12.3	6.6
1.85V	347	298	242	156	119	96	81.9	71.3	58.5	49.0	31.6	21.6	11.7	6.4
1.90V	262	254	193	136	106	89	76.2	65.8	53.0	44.1	28.5	19.8	11.0	5.9

Discharge Data with Constant Power Units: Watts per cell (25°C, 77°F)

End voltage	15min	30min	1h	2h	3h	4h	5h	6h	8h	10h	16h	24h
1.60V	1086	860	658	361	275	218	183.4	159.0	131.8	110.7	71.5	48.5
1.65V	1034	814	612	359	273	217	182.1	157.5	130.9	109.9	70.9	48.1
1.70V	987	777	573	354	269	214	179.6	155.4	129.1	108.4	70.0	47.5
1.75V	934	746	540	344	262	205	173.3	152.5	127.0	106.4	68.7	46.8
1.80V	874	716	509	332	255	200	165.3	144.8	121.0	101.0	65.2	44.3
1.85V	818	688	474	319	243	191	160.9	138.7	115.0	96.8	62.5	42.5
1.90V	764	628	422	290	234	182	156.1	125.8	104.3	87.8	56.7	38.5

stored energy solutions for a demanding world

NARADA

Model: **70PzV500**

Ares series

Dimensions-mm[inch]

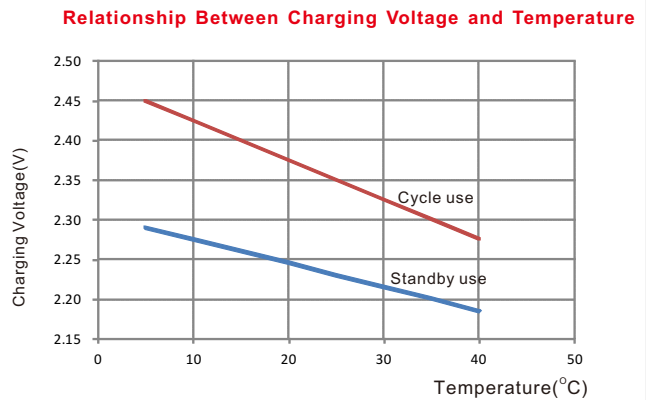
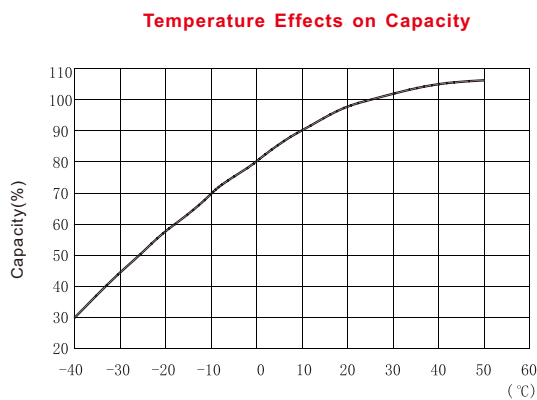
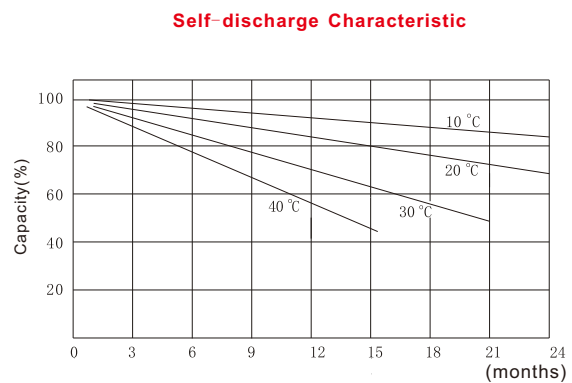
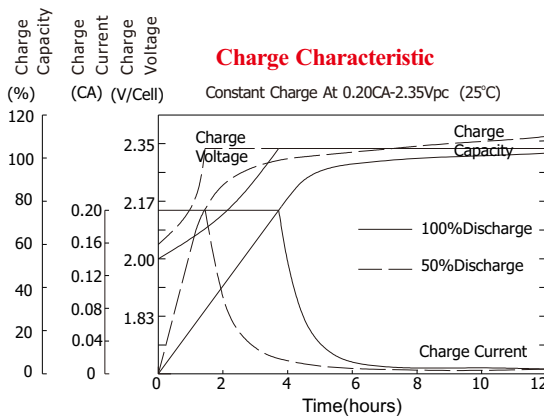
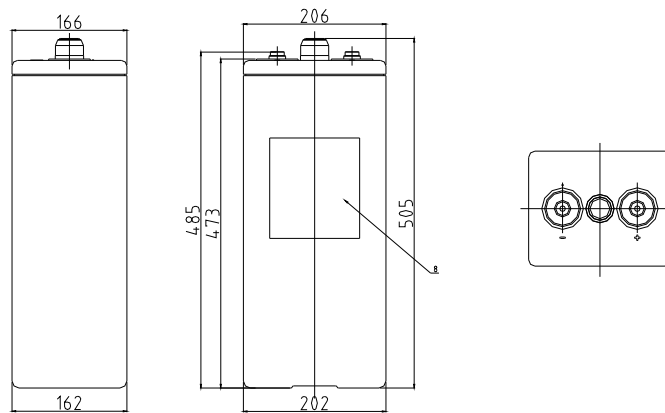

NARADA POWER SOURCE CO.,LTD.
 9F, Building A, No. 50 Zijinghua Road, Hangzhou, China
 Tel:+86-571-28827013 Fax:+86-571-28828290
 Website:www.naradabattery.com E-mail:intl@narada.biz

NARADA ASIA PACIFIC PTE.LTD.
 65 Ubi Crescent #07-05 HOLA centre, Singapore
 Tel: +65-6848 1191 Fax: +65-6749 3498
 E-mail: sales@narada.com.sg

NARADA EUROPE (UK) LIMITED
 Spectrum House, Dunstable Road, Redbourn,
 St. Albans, Herts AL3 7PR
 Tel: +44 (0)845 371 7095 Fax:+44 (0)845 612 2031
 E-mail: sales@naradaeurope.com

